

S-SCF Series, S-SF Series

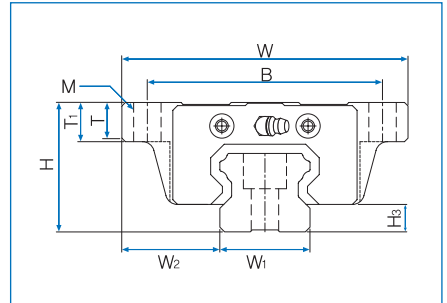

Model No.	External dimensions			Dimensions of block									H ₃
	Height H	Width W	Length L	B	C	M	L ₁	T	T ₁	N	E	Grease nipple	
S 15SCF	24	52	40.2	41	—	M5	24	6	7	6	6	A-M4	4.5
S 15SF			56.9		26		40.7						
S 20SCF	28	59	47.2	49	—	M6	27.6	8	9	5.5	12	B-M6F	6
S 20SF			66.3		32		46.7						
S 25SCF	33	73	59.1	60	—	M8	34.4	9	10	6	12	B-M6F	7
S 25SF			83		35		58.3						

Composition of Model No.

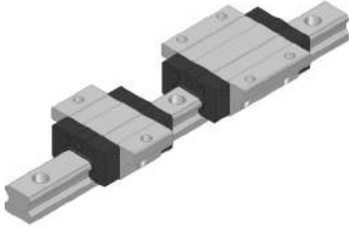
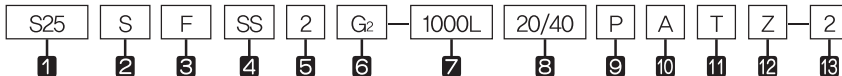

- 1 Model No. of Linear Motion Guide
- 2 Type of block : No symbol—Full-ball type / S—Spacer Chain type
- 3 Form of block : C—Rectangular short type / R—Rectangular standard type / CF—Flange short type / F—Flange standard type
- 4 Type of seal : UU—End seal / SS—End seal + Inside seal / ZZ—End seal + Inside seal + metal scraper
UULF—End seal + LF seal / SSLF— End seal + Inside seal + LF seal / ZZLF - End seal + Inside seal + metal scraper + LF seal (*1)
- 5 Number of blocks combined in 1 rail
- 6 Symbol of clearance : No symbol—Normal preload / G₁—Light preload / G₂—Heavy preload / G_s—Special preload (*2)
- 7 Length of rail
- 8 Size of G value : standard G value has no symbol.
- 9 Symbol of precision : No symbol—Moderate precision / H—High precision / P—Precision / SP—Super Precision / UP—Ultra Precision (*3)
- 10 No symbol—Rail counter bore type (A topside assembly) / A— Rail tap hole type (an underside assembly) (*4)
- 11 Connection symbol
- 12 Special symbol
- 13 Number of axis used on the same surface

(*1) See P77 Symbol List of Optional Parts (*2) See P17 Radial Clearance

(*3) See P24 Selection of Precision Class (*4) See P59 The reference for standard tap hole type of a rail

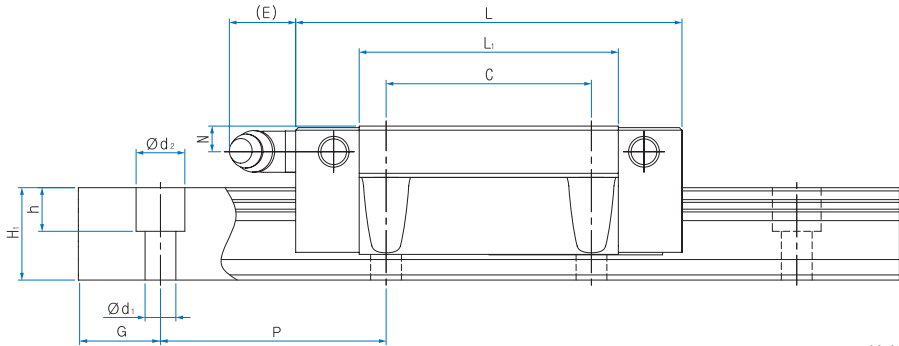

Unit : mm

Dimensions of Rail						Basic load rating		Static allowance moment kN · m					Mass	
Width W1 ±0.05	W2	Heigh H1	Value G	Pitch P	d1 x d2 x h	C kN	Co kN	Mp		My		Mr	Block kg	Rail kg/m
								1	2(Contact)	1	2(Contact)	1		
15	9.5	13	20	60	4.5x7.5x5.3	8.3	10	0.042	0.224	0.042	0.224	0.079	0.125	1.3
						12.1	16.2	0.115	0.552	0.115	0.552	0.129	0.203	
20	11	16.5	20	60	6x9.5x8.5	11.1	13.1	0.063	0.342	0.063	0.342	0.137	0.187	2.2
						16.1	21.2	0.173	0.838	0.173	0.838	0.223	0.301	
23	12.5	20	20	60	7x11x9	17.9	20.4	0.123	0.670	0.123	0.670	0.246	0.320	3.0
						25.8	33.1	0.337	1.636	0.337	1.636	0.398	0.527	

1N=0.102kgf

